

**Schicht S1 - S1** M = 1:20  
Quadermauerwerk Sockel - Ausführung 1x

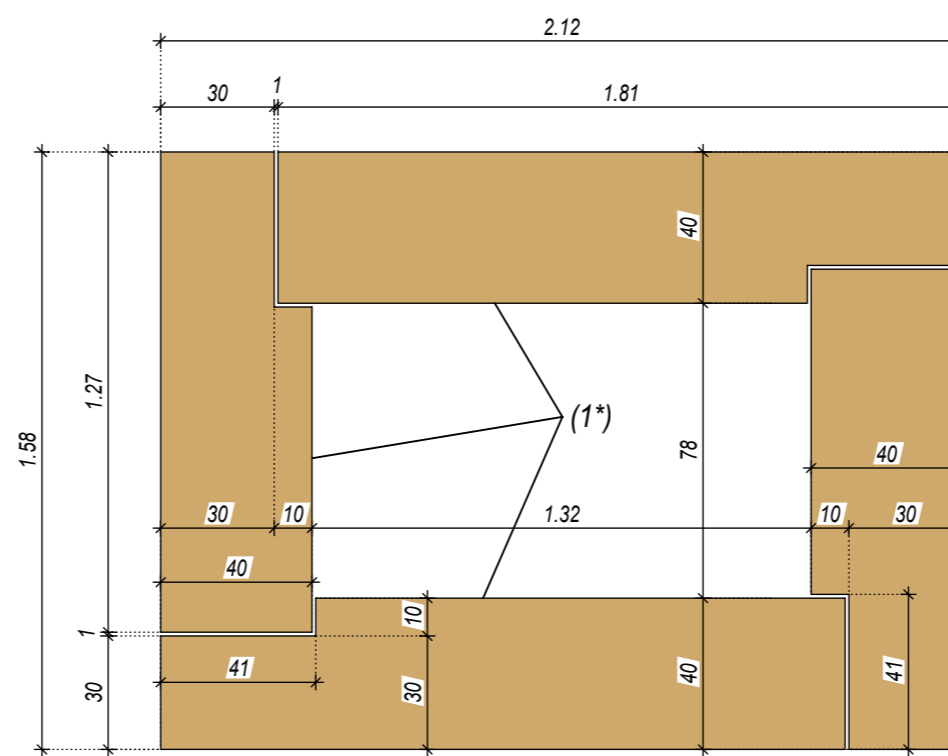

**Schicht S2 - S2** M = 1:20  
Sockelgesims - Ausführung 1x

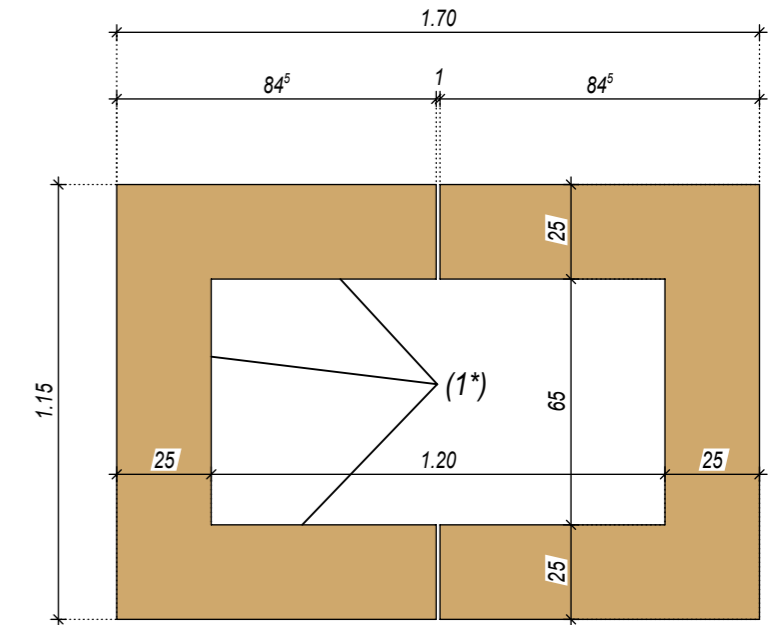

**Schicht Q1 - Q1** M = 1:20  
Quadermauerwerk - Ausführung 1x

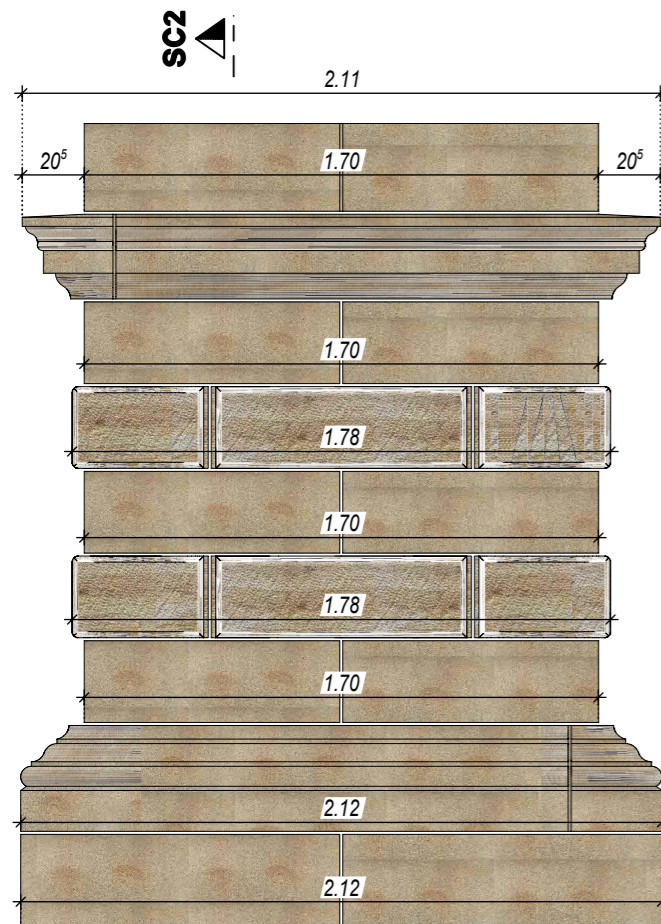

**Ansicht Westen** M = 1:25

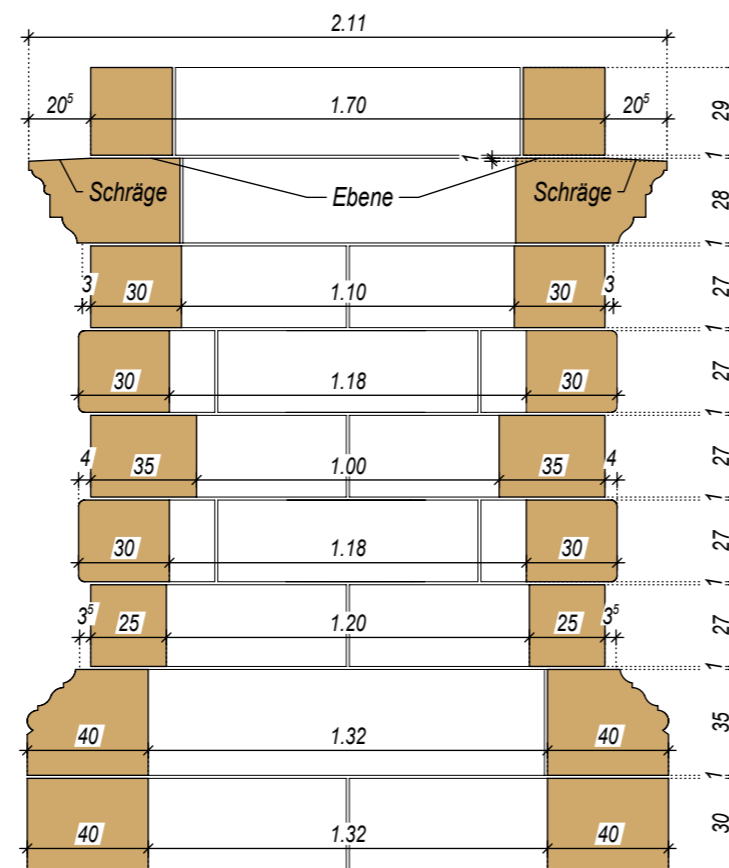

**Schnitt SC1 - SC1** M = 1:25

- K** - Kämpferschicht
- G** - Kämpfergesims
- Q3** - Quadermauerwerk
- B2** - Bossen
- Q2** - Quadermauerwerk
- B1** - Bossen
- Q1** - Quadermauerwerk
- S2** - Sockelgesims
- S1** - Quadermauerwerk Sockel

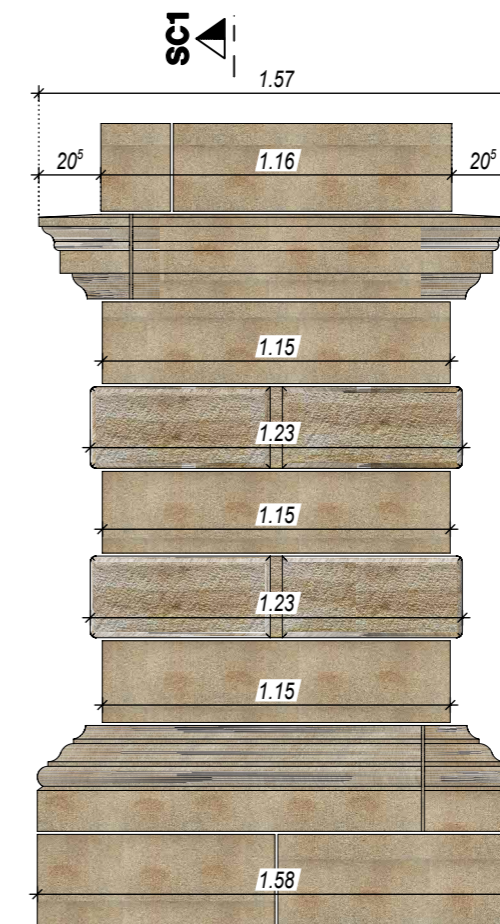

**Ansicht Norden** M = 1:25

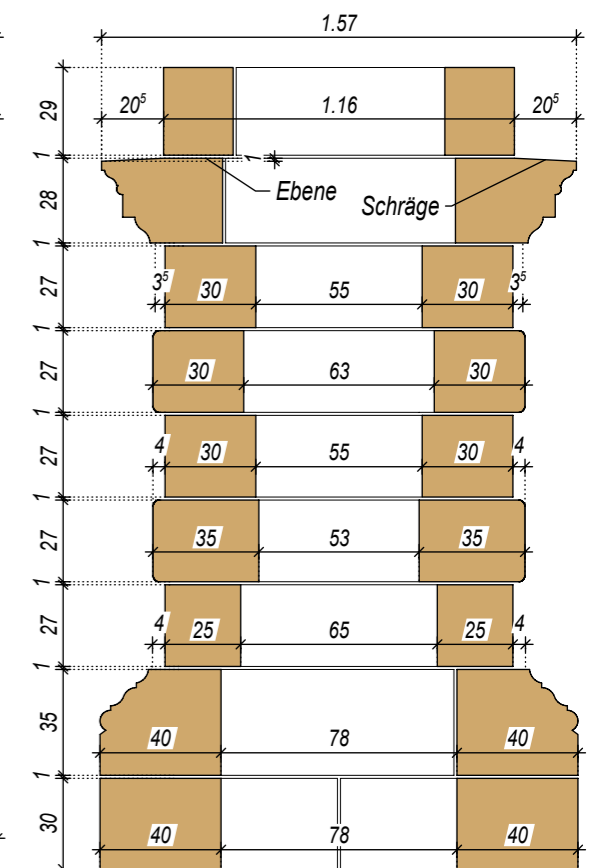

**Schnitt SC2 - SC2** M = 1:25

**GOTHA, SCHLOSS FRIEDENSTEIN / SANIERUNG U. UMBAU - TP II.1**

Bereich: Westflügel, Arkadenpfeiler 1.BA - Natursteinarbeiten Planungsstand: 30.01.2026

Schichtenplan 01

5\_WF\_ARK\_SAN\_102\_a